

User instructions

Haapsalu Uksetehase AS gives its quality doors a **two year guarantee**. Guarantee covering defects by reason of faulty material or workmanship does not cover deviations in quality due to normal wear and tear, for example, wearing off of the finish of the threshold, changes in door adjustment, etc. In order to enjoy our products for years, we strongly recommend to abide by the following recommendations and instructions.

In order to keep this guarantee valid, it is forbidden to:

1. Use or store **interior doors or their details (door frames, thresholds)** in unheated or damp rooms.
2. Store **interior doors or their details** in conditions where they are in contact with water or allocated to constant moisture.
3. To alter the size of the doors or door frames by sawing.
4. To fasten non-standard fittings on doors or door frames (when fittings are needed, please consult our sales representatives).
5. To damage doors or door frames mechanically.
6. To allocate painted or varnished surfaces or seals to chemicals.
7. To repaint or varnish doors or their parts.

Installation instructions:

1. Make sure the door opening is of sufficient size, i.e. 15 - 40 mm larger than the dimensions of the door frame. If not, change the dimensions of the opening.
2. Make sure the opening is rectangular and level. If not, rectify the opening.
3. Assemble the door frame (see figure 6) by screwing the overhead part and the threshold (not included in the set) together with the door jambs so that the door will open in a way as desired. **Drill the screw holes first.**
4. Place the door frame into the opening and fix with wedges to a vertical position. **Note:** doors are meant to be installed on the flooring. Make sure the surface under the threshold is smooth and level. If needed, support the cavity under the threshold with wedges or wooden blocks to avoid its deflection when stepped on.
5. Mark the installation openings in the wall, drill the dowel holes and install dowels. Door frames can be fixed to wooden structure with wedges and then fastened with screws.
6. Place the door frame into the opening and fix with wedges to a vertical position.
7. Fix the door frame with screws and make sure with a long ruler or a level that the door jambs are straight.
8. Place the door panel on hinges and fix the hinges with cross-head bolts (bossed doors) or with hinge screws (doors with straight edges). Bossed doors must also be fastened with two screws 4,5 x 30 (not included in the set). **See figure 4. In case of a garage door, see the installation instruction of the lifting mechanism.**
9. Make sure the door is moving freely and the latch-bolt/roll closes properly. If not, change the position of the door frame by adjusting screws so that the door will move freely and the latch-bolt/roll will close easily (protrusion of the roll can be regulated by adjusting the screw). In order to change the way of opening of the latch-bolt (Boda 2014 and 2011) pull the tumbler with pliers outwards until it is possible to turn it around 180 degrees. **See figure 1.**
10. Seal the gap between the door frame and the wall with installation foam following relevant instructions. **Note:** In case of fireproof door, seal with special foam or mineral wool. **Note:** If you use too much foam between the door frame and the wall, there is a danger that the door frame will deform when foam hardens and it will be impossible either to use the door at all or at least use it properly. To avoid that place 1 or 2 horizontal supports between the door jambs before applying the foam making sure you do not damage the surface of the door frame. Use cardboard or other soft materials between the jambs and supports. It is recommended to keep the supports in place until the foam has entirely hardened (up to 12 hours). **See figure 5.**
11. Fasten the threshold to the floor by drilling screw holes and phase for the screw head first.
12. Install battens and finish door reveals up to the door frame. Protect the door and frame with plastic and tape. **Note:** remove the tape immediately after you have finished the works.
13. Install necessary door furniture (handles, door closers, labels, etc.).
14. Check once more that the door moves freely and closes properly. Adjust the screws, if needed. **See figures 2, 3, 4.**

Use and maintenance instructions:

1. Make sure regularly that the lock, hinges and handle are fastened and work properly. Tighten the screws, if needed.
2. Clean the surface of painted, varnished or laminated doors with soft cloth and household cleansing agents of general purpose diluted with water in indicated ratio.
3. For cleaning doors with teak veneer, use dry cloth. If needed (recommended once a year), renew the finish of the door surface with shading wood protective agents Kolorex Protect (Tikkurila) or Valtti Color Extra (Tikkurila).
4. Lubricate (preferably with silicone oil, which does not stain and is in aerosol container) hinges, tumbler and latch-bolt at least once a year. In case of a garage door, lubricate also the moving parts of the lifting mechanism and working surface of the bar.
5. Do not attempt to open or close the door by force, if it is difficult due to the contact between the frame and the panel – you might damage the frame or the panel. Adjust the position of the door panel, because there have been changes in the construction of the building, wood has swollen due to dampness or hinges or the lock have been loosened a bit. **Please turn to the company, which installed the door, if help needed.**
4. Keep doors (especially doors with glass) from closing with a swing due to the draught.

In case of complaints, please turn to the dealer you purchased the door from or to the Quality Manager of Haapsalu Uksetehase AS. It is necessary to have the retail sales check or the invoice.

Figure 1. (Changing the way of opening)

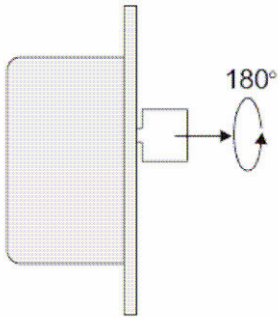

Pull the tumbler out and turn it around (use pliers, if needed)

Figure 2. (Adjusting hinges)

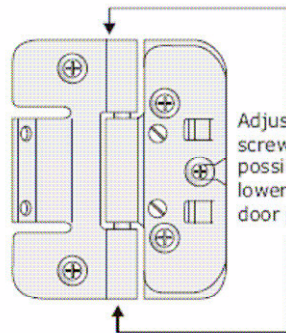

Adjusting these screws makes it possible to lower or lift the door panel

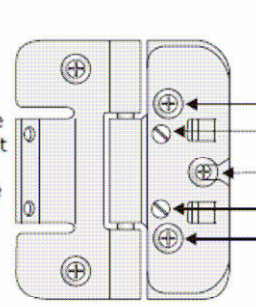

Fixating screws

Adjusting these screws makes it possible to move the door panel to the right or to the left.

Figure 3. (Adjusting hinges)

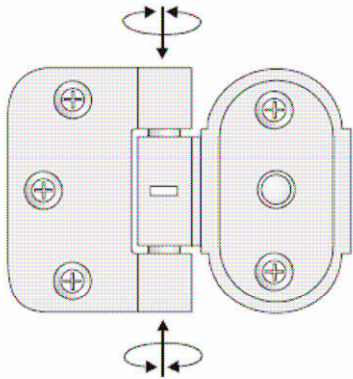

To lift the hinge, turn the upper screw outwards and the lower screw inwards.

To lower the hinge, turn the lower screw outwards and the upper screw inwards.

Figure 4. (Adjusting hinges)

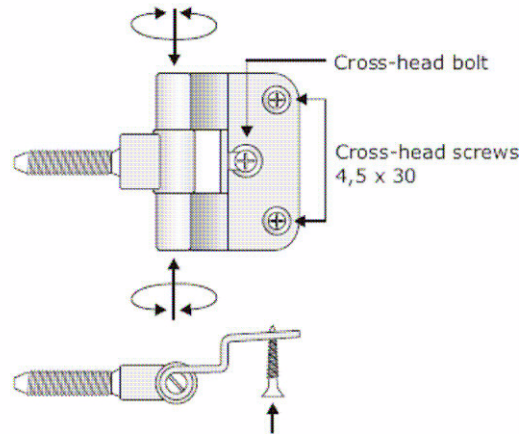

Cross-head bolt

Cross-head screws 4,5 x 30

Figure 5. (Assembly of the door frame)

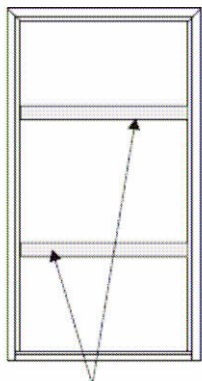

Horizontal supports

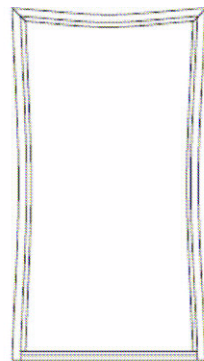

Deformed door frame after applying foam

Figure 6. (Assembly of the door frame)

After the installation of the door frame fasten with screws to the floor

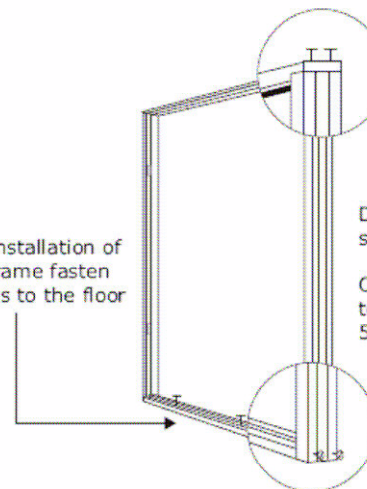

Drill the holes and screw in screws.

Overhead is recommended to fasten with screws 5 x 80 mm